

TAPMATIC



SYNCHROFLEX SFT Modular Straight Shank

Double your tap life and improve thread quality

It's Unique. No other tap drivers, not even those "retro" collet holders that promise to deliver "just the right amount of tension and compression" through springs or cushioners of plastic and rubber, can do what SynchroFlex® does. We guarantee that Tapmatic SynchroFlex® will work better, produce longer tap life and more accurate threads than any other tap drivers on the market.

For rigid tapping applications, Tapmatic's patented SynchroFlex® tap drivers with internal coolant feature a precision machined flexure between the shank and the chuck. This design compensates axially and radially for the unavoidable minute discrepancies between the machine feed and traverse and the actual thread pitch and hole location. Any deviation at all from the correct feed rate for the thread pitch or the precise hole location results in added wear on the tap. SynchroFlex® allows the tap to reproduce itself exactly for maximum tap life and better thread quality.

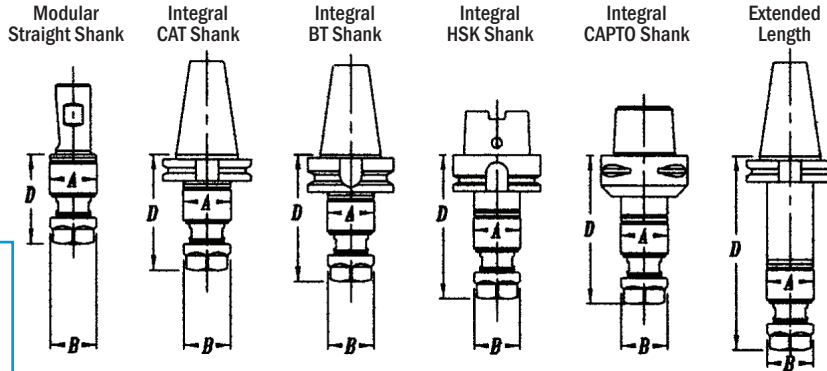

Please Specify "D"



ER Tap Collets also available



Pricing shown for straight shank tools only. Pricing for taper shank tools available on request.

Model No.	Capacity in 1010 Mild Steel	Mount	Collet Series	A	B	D	Axial Comp.	SPECIAL
SFT10II-1.00-ER11	#2 - #10-32 M2 - M5	1.00" Straight shank	ER11	.925	.740	2.09	± .020	\$729.95
SFT50II-1.00-ER20	#8 to 1/2"-20 M4 - M12		ER20	1.362	1.340	2.49		\$729.95
SFT75II-1.00-ER25	3/8" to 3/4-10 M10 - M20		ER25	1.733	1.650	3.26		\$896.95
SFT100II-1.00-ER40	5/8" to 1" M18 - M30		ER40	2.440	2.480	4.39		\$1,599.95

SFT Modular Straight Shank with Quick-Change Spindle Also Available

SPECIAL PRICING EXPIRES DECEMBER 31ST, 2021



BERCOR Industriel Inc.

4253 rue de la Garlock, Sherbrooke, QC. J1L 2C8

Téléphone: 819-820-7477

Sans-frais: 1-877-565-1788

TAPMATIC

Tapping Attachments for Manual Machines - RX Series

Features & Performance:

- Higher production rates
- New durable, rugged design
- New heavy duty ball clutch
- Pre-selective torque drive prevents tap breakage
- Accurate depth control
- 1.75 x 1 Increased reverse speed
- Self-feed ensures gage perfect threads
- Re-entry cushion eliminates cross threading
- Longer tap life
- Consistent trouble free performance



SAVE!

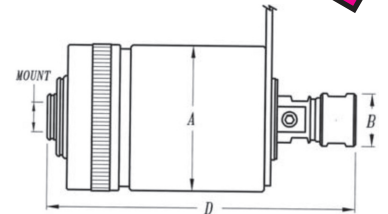

Torque Bars available
Always mount a torque bar to hold the tapping attachment's stop arm from rotating. The Torque Bar must be mounted securely to the table or quill of your machine. The torque bar installation must be stronger than the largest tap in the tool's capacity.

Model No.	Capacity in 1010 Mild Steel	Mount	Collet Series	*Rec. Max. Speed	Weight	A	B	D	*Self Feed	SPECIAL
RX30-33JT	#0 - 1/4" M1.4 - M6 Roll Form #10 Max	#33 JT	#21000	2000 RPM	1.5lb .70kg	2.125" 53mm	.750" 19mm	4.58" 116mm	.13" 3mm	\$799.95
RX50-33JT	#6 - 1/2" M3 - M12 Roll Form 3/8" Max NP 1/16", 1/8"	#33 JT	#22000	1500 RPM	4.0lb 1.8kg	3.000" 76mm	1.070" 27mm	6.20" 157mm	.20" 5mm	\$1,099.95
RX70-3JT	#10 - 3/4" - 16 M5 - M18 Roll Form 9/16" Max	#3 JT	#24000	750 RPM	6.7lb 3.0kg	3.500" 88mm	1.450" 36mm	7.14" 182mm	.27" 7mm	\$1,599.95

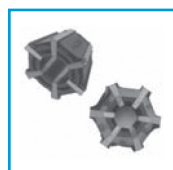

Rubber Flex Collets



Arbors available

Collet Series	Cat. No.	Tap Size	Shank Size	SPECIAL
For RX30	21600	#0 - #8 Standard	.098 - .177	\$119.95 EACH
	21700	#10 - 1/4" Standard	.177 - .256	
For RX50	22100	#0 - 1/4 Standard	.139 - .257	\$119.95 EACH
	22200	1/4" - 1/2" Standard	.253 - .383	
For RX70	24100	#10 - 1/2" Standard	.176 - .383	\$129.95 EACH
	24000	5/16" - 5/8" Standard	.280 - .500	
	24500	3/4" Standard	.393 - .590	